



BUDGETARY OFFER

FOR

**SUPPLY OF ROCHEM PT-RO MEMBRANE SYSTEM
FOR CETP TREATED EF FLUENT RECYCLE**

SUBMITTED TO

**SMS ENVO CARE LIMITED
For FATUHA CETP**

BY

ROCHEM SEPARATION SYSTEMS (INDIA) PVT. LTD.

TEL: +91-22-67049000
FAX: +91-22-67049010

E-mail: rochem@rochemindia.com

RSS/0116/2017 Rev 02 dated 30.07.2019



CONTENTS

Sections	Description	Page No.
1.	Cover Letter	3
2.	Introduction To Application & ROCHEM's Experience	4
3.	Comparison between ROCHEM PT-RO and Conventional Spiral RO	12
4.	Rochem RO Installations	13
5.	Block Diagram	14
6.	Technical offer	15
7.	List and Specification of Main Components	17
8.	List of Civil Units	34
9.	Battery Limits, Scope & Exclusions	35
10.	Specification Unit Parameters Reference RO feed analysis	37
11.	Specification Unit Parameters Reference RO permeate analysis	38
12.	Price Table	39
13.	Commercial Terms & Conditions	39
14.	Operation & Maintenance	40
	Warranty	41

To,
M/s SMS Envocare Limited
20,IT Park,Parsodi,Nagpur-440022

Rochem Separation Systems (India) Pvt. Ltd.
101, HDIL Tower, Anant Kanekar Marg,
Bandra (East), Mumbai 400 051.
Tel: 91-22 6704 9000
Fax: 91-22 6704 9010
Email: rochem@rochemindia.com
Website: www.rochemindia.com
CIN- U24100MH1991PTC064068
Date: 30th July, 2019
Ref: RSS/0116/2017 Rev 02

Kind Attention : Mr. Kishore Malviya

Mr. K. K. Sinha

Subject : Budgetary Proposal for the supply of ROCHEM ZLD System for Effluent
Recycle FOR FATUHA CETP.

Dear Sir,

We thank you for your interest in ROCHEM Technology & Solutions for effluent treatment/recycle. With reference to your discussions had with our Mr. DP Rajesh, we are pleased to submit our budgetary offer for Rochem Membrane system to recycle effluent of capacity 1.2 MLD at Fatuha CETP for your kind perusal.

We offer 3-stage RO system on the CETP treated effluent to recover ~ 96.8% reusable permeate. The balance rejects can be evaporated in MEE. Based on preliminary discussions & data provided by your goodselves we have proposed this scheme assuming remaining parameters. In case there is a change in parameters our offer is subject to change techno-commercially.

The offer covers our submissions as follows:

1. Technical details
2. Details of civil tanks
3. Typical Process flow diagram
4. Area requirement
5. Cost of Electromechanical, instrumentation scope of supply

Also included please find our reference list of installations where we cater to effluent volumes in MLD capacity.

We trust that you would find this system very effective in providing a solution towards total water management.

Thanking you,
Yours Sincerely,

FOR ROCHEM SEPARATION SYSTEMS (INDIA) PVT. LTD.

GIRISH THORAT
(GENERAL MANAGER-INDIA)

(e: Quotation/Consultant/SMS/Patliputra/Offer_1.2MLD ZLD_Fatuha Rev 02.doc)

Section 2: Introduction To Application & Rochem's Experience

1. Rochem Introduction

Rochem Separation Systems (India) Pvt. Ltd. was established in 19th November, 1991 under Indian Companies Act, 1956 with an aim was to enter the field of Water Purification and accordingly the Company entered into Technical Collaboration with ROCHEM Group A.G. The Collaboration scope was extended by ROCHEM Group investing in 50% Share Capital of the Company. This collaboration made it possible for the company to offer following systems:

1. Reverse Osmosis (RO):

The majority of dissolved salts, organics, bacteria and suspended solids are unable to physically pass through the membrane and are discharged in the concentrate. The pure water is recovered.

2. Nanofiltration (Nano):

Almost like RO, it also removes many of the harmful metals and organics. However, it will allow sodium chloride (salt) to pass through.

3. Ultra Filtration:

This membrane process is used to separate large molecular substances. It will reject all bacteria and is effective to disinfect domestic water supplies.

Considering the Indian Market and the competition the Company decided to enter the market concentrating on

- Sea Water Desalination as First Phase.
- Ground / Brackish Water Desalination as Second Phase.
- Industrial Waste Water Purification for Recycling and Reuse.

We are pleased to submit you that ROCHEM had entered into strategic alliance with its channel partners to provide its customer the TOTAL WATER MANAGEMENT SERVICES. As part of this service ROCHEM now provides all solutions to your wastewater problems at "ONE STOP". Now for all zero discharge requirements, we shall be pleased to offer you solutions.

We undertake projects to provide you detail designing and engineering, manufacturing and supply of the Pre-treatment, ETPs, special custom made equipment, thermal evaporators (MEE), Total water management and Zero discharge solutions.

Over its first decade of operation, Rochem Separation Systems expanded its business with the Indian Navy, India Coast Guard and Shipping Corporation of India with a majority of the Indian Naval & Coast Guard Ships & Submarines (> 95%) having Rochem Installations on Board for Sea Water Desalination.

The technology was aptly supported by after sales service in various locations along the coastal areas of India for providing support and service to its Customers.

It was in this backdrop the Company made the conscience shift towards treatment of wastewater from various industries in the year 1999. After gaining experience from Rochem Worldwide in application of water recovery from Leachate, the company studied various industry effluents and devised applications of its technologies to recover water to be reused within the process.

Pharmaceutical, Distillery and Textile were the first major industries studied by the company. The aim was to achieve not just a product that can recover water but also provide cost saving to the Customer.

The concept of Reverse Osmosis as a Tertiary Treatment Technology was challenged successfully with the development of Systems that in the Textile and Distillery Industries could be applied to the Raw Effluent i.e. at the Primary Stage and in the Pharmaceutical Industry in the Secondary Stage. The result was not only reusable quality water but also a cost saving in terms of Chemical and Electricity cost in the Conventional Effluent Treatment Plants.

The stumbling block to the Company was the Consumers Perception of the RO Technology. It was looked at as a failure in Effluent Treatment. The two major reasons being the Configuration of the Old Module and second the application of it vastly being in wastewater by the unorganized sector.

The Company sought to overcome the hurdle by the introduction of Fixed Price Operations & Maintenance Contracts for its supplied systems. The company took the entire responsibility of its supply including membrane replacement at its operating cost plus an additional charge towards its supervision services.

The entire idea was to assure the customer of the quality and performance of the system and Rochem's confidence of its technology. Today Rochem's advantage lies in not just its superior technology but in its superior systems aptly supported by its efficient and extensive after sales support.

Rochem India boasts of the only facility to manufacture PT-RO Systems outside of the parents Hamburg facility. These systems conform to the German Standards and are built in accordance with the Companies Certified ISO 9001 Procedures.

Rochem today has expanded its product line to include a diverse range of applications from Sewage to Wastewater and Sea Water to Brackish and River Water. The total strength of the Company is >300 Employees and a wide Agent Network supporting its services in all major Industrial centres. Over 200 of these Employees are in the after sales service network of the company.

Esteemed clients of the Company include The Indian Navy, Coast Guard, Shipping Corporation of India, Oil & Natural Gas Corporation, Aurobindo Pharma, Kanoria Chemicals & Industries, GMR Technologies & Industries Ltd., Rajasthan Spinning & Weaving Mills Ltd. (Mayur Suitings), Shaw Wallace & Company Limited, Biocon India Limited, India Glycols Limited, Balrampur Chini Mills Ltd., Shasun Chemicals & Drugs Limited, Somaiya Group, etc.

Rochem has provided its customers for more than a decade not only a breakthrough technology but systems which are versatile and rugged to perform under the toughest conditions. At the same time they lend the customer the flexibility to implement the project in phases by making increase in capacity and recovery possible.

“Water Water Everywhere Every Drop Fit to Drink!!” With the current world scenario of decreasing water availability for consumption, it is imperative we conserve this precious resource and maximize its use. World statistics indicate India as among the countries having vast water resources, however at the bottom of the table for times water recycled.

The cost of Environment Degradation sadly cannot be estimated and added to our Balance Sheets but it's a contingent liability that is exceeding legitimate proportions. We at Rochem are encouraging small steps to a better future.

a) Reverse Osmosis

Reverse Osmosis is at present a proven technology in world desalination scenario and contributing bulk quantum in global consumption for various applications. Today the impressive demand for desalination has been a major thrust for improvement and refinement of this technology. The major problem with RO desalination plants and their application limitation is their susceptibility to fouling and scaling, the implications of which are usually irreversible membrane damage, reduced flux rates, & increased capital and operating costs.

Therefore selection of a proper module configuration available for Reverse Osmosis Membrane Applications is the crux of the issue. The selection of a particular configuration depends on their relative characteristics.

The following are the commercially available RO membrane configurations:

- A. Spiral Wound Module (SW)
- B. Hollow Fine Fibre Module (HFF)
- C. Plate & Tube Module (PT)

A) Spiral Wound

In a spiral wound module, the membranes are separated and a feed channel is produced by wrapping a piece of mesh spacer between membrane layers. This spacer (provides only approx. 3 micron spacing between membranes.) Creates a primary difficulty in the use of spiral wound modules. The mesh greatly reduces the amount of open flow area between membranes and acts as inline filter and traps suspended solids in feed stream. The spacer creates eddies and zones of zero flow where biological growth and fouling occurs in the module. Typically lengthy flow path of 40 inches and above results in build-up of polarization concentration that increase scaling and fouling.

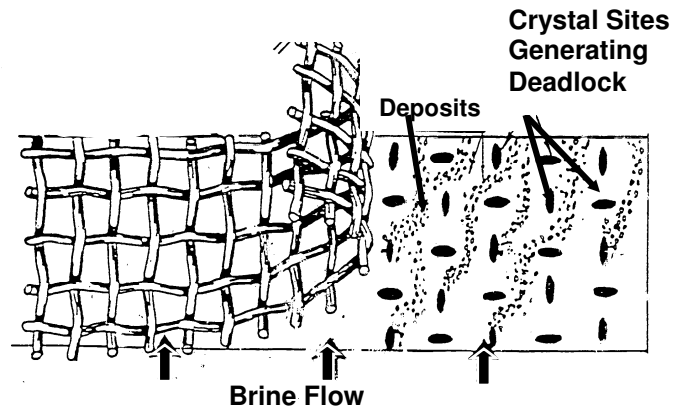

B) Hollow Fine Fibre

The hollow fine fibre modules have hollow fibres with approx. millions of hollow fibre capillary tubes pressed together which give even smaller channels for a continuous flow of water through that module.

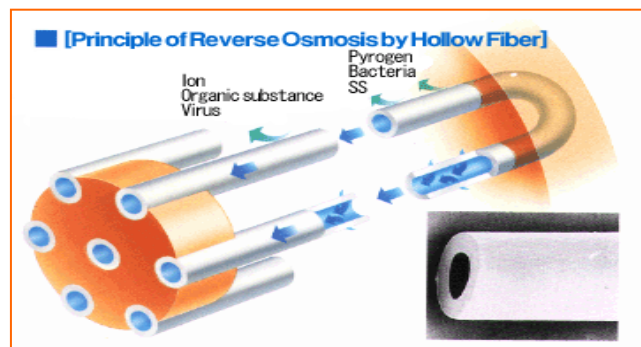

Major Concerns in Reverse Osmosis Membrane Filtration:

A) Particulate fouling:-

What & why? – Sea water contains suspended particles ranging from colloidal to sub-micron and higher micron range particles. These particles pose a potential threat to the membrane modules as they can get trapped inside the membranes and choke up the entire module.

Solution! – All membrane systems are designed with a pre-filtration to remove these particles from the raw sea water entering the membrane modules. Particle sizes varying from colloidal – sub-micron to higher micron range this prefiltration system has to be designed to tackle all types of particles. Generally the particle filtration systems consist of media filters for removal of coarse particles and cartridge type filters for removal of fine particles.

It is essential to maintain a good turbulent flow through the membrane module in ensure minimum obstructions are present in the flow path to avoid trapping of these particles in the module.

Conventional Membranes – While it is best to completely eliminate all particles to prevent particulate fouling, the removal must meet the requirements of each module type. Due to its construction, as explained earlier, the spiral wound membranes have only a 3 – 5 micron flow path for the sea water entering the module, further the feed spaces (mesh) acts as an entrapment for particles. Hence it is important to not only reduce particles below 3 micron but smaller as well to avoid build up along the feed spacer (mesh) as depicted below.

This treatment becomes necessary to reduce the silt density index or in other words the blocking index for the membranes up to a factor of ideally as close to 1 as possible and maximum 3. These factors for the SDI will be measured by a very fine special water-filter of a size 0.45 micron. The period of time in which this filter gets choked gives the number as a factor in minutes. The lower this factor, lesser the suspended solids in the seawater entering the membrane. For a spiral wound and hollow fibre-membrane this factor is 1. Normally, natural clean seawater will have a factor of 3 to 5, near coastal areas such factor can increase to 20 or more and even in the range of rivers this factor can be 30 to 40.

The particles of higher micron ranges can be removed by suitable media filters followed by cartridge type filters of suitable rating, down to 2 microns. However these filters are not capable of removing smaller suspended or colloidal matter from the seawater. For removal of such fine particles it is essential to use coagulant, flocculent aids which enable removal of these fine particles as flocs by media/cartridge filters.

Hence we see that there exists a real need for Coagulant dosing followed by fine cartridge filtration of avoid Particulate fouling of Spiral wound membrane modules. To solve the problem of clogging of these membranes, it is necessary to keep the suspended solids in the waste water for the membranes lower than factor 3, which only can be carried out by an extensive Prefilter water treatment.

Rochem Plate & Tube (PT) Module Membranes – Unlike conventional membrane modules, such as spiral wound, the design of the Rochem PT module (refer Pg 10) facilitates an open feed flow path of 1 mm over the RO membranes. Further the PT module is designed with Hydraulic Plates as membrane spacers. These hydraulic Plates enhance turbulence in flow and do not act as entrapment for particulate matter in any way. This large clearance in the feed flow path means that finer particles entering the module cannot get trapped and will flow out along with the reject water stream at module outlet.

Hence all Rochem Sea water desalination systems worldwide use only Media filters for coarse filtration followed by 10 micron cartridge filters for fine filtration. Thus the reduced Potential for particulate fouling in the PT module justifies the minimum prefiltration requirement.

B) Biological Fouling, Scaling, Cleanability & Life.

To overcome such problems, an extensive pre-treatment for the raw waste water by using different chemicals has to be carried out. This includes Chlorine dosing to kill the bacteria and other micro-organisms, Sand-filtration with coagulant-dosing, Anti-scalent dosing, backwash filter, Flocculent dosing (Polyelectrolyte inside the coagulation filter), De chlorination to remove residual chlorine (since it is harmful to membranes) and Acid-dosing to neutralize the water before it enters the membrane.

Thus, a typical layout of the spiral wound / hollow fibre module based RO plant may have a number of pre-treatment stages as follows:

- a. Chlorine dosing
- b. Coagulant dosing
- c. Polyelectrolyte dosing
- d. Coarse Filtration
- e. Fine filtration
- f. Antiscalent dosing
- g. De-Chlorination
- h. Micron Filtration (Up to 5 μ)

The above pre treatment is necessitated due to inherent bio-fouling, colloidal fouling and scaling that is prevalent due to the peculiarity of construction of these membrane types.

In these conventional module-types the wastewater must try to find the best way to flow through and hence it cannot ensure equal velocity of the wastewater along the entire membrane surface area. This is further aggravated due to small particles entering inside such type of membranes and commencement of micro-organism growth on the membranes surfaces. The water will normally take the easiest path to flow through and will bypass such sections where these particles give resistance against the normal wastewater flow. In other words, the membrane surfaces begin to get blocked up. The active sections of membrane surfaces available to desalinate the wastewater thus reduce more and more up to the point, where the active surface of the total module will be very small. The manufacturers of plants with these membrane types even offer a cleaning-system for the membranes, in case the particles stop the desalination process. These cleaning solutions can only lift up these particles from the membrane surfaces and try to transport them out of the modules. But due to the very small channels and passageways for the water, it is nearly impossible to drain out these trapped particles. That means in practice these module channels will be totally blocked and cannot be used for further desalination and have to be renewed in a very short operation time.

Though RO plants are viewed by the potential users as the technology that consumes less energy and as being low capital intensive, the following disadvantages are also weighed in more seriously.

- a. Stringent and Complex pre-treatment system, pH maintenance.
- b. Membrane fouling due to high salt content and suspended solids.

The following statement by various membrane manufacturers remains valid and relevant even today for Spiral and Hollow Fine fibre membranes.

“The key for a proper and reliable operation of RO membranes is in the pre-treatment”.

To overcome these problems which plagued the Reverse Osmosis desalination technology until the mid 1980's, ROCHEM developed their state of art Plate and Tube™ module after considerable research and trials. The main feature of such membrane configuration is the steady continuous waste water velocity over all sections of the membrane surface and the big channels between the membrane and the Plate surface which means an open-channel-operation.

ROCHEM's PT membrane module has been conceived for tackling this exact difficulty of Spiral wound and Hollow film fibre membranes to purify waste water.

Rochem Plate Tube Module

The problems of earlier configurations, the configurations that reflect ease of manufacture rather than operational effectiveness, have been overcome by the state of art Plate and tube membranes module technology in all applications ranging from waste water desalination to industrial waste water treatment.

It is constructed from a series of octagonal membrane cushions separated by a series of plastic spacer Plates. The Plate support the membrane cushions but leaves an open channel flow path through module. The flow path is radial and gets reversed in 180° to flow over other side of cushion. This flow path repeats for each membrane in stack. The resultant turbulence due to reversal eliminates the concentration polarization minimizing scaling & fouling.

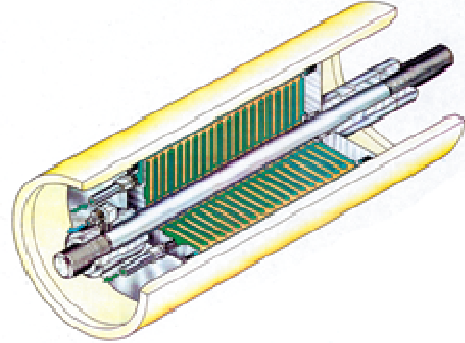

A comparison of these membrane modules on the basic parameters is reproduced as below:

<i>Module Configuration</i> <i>Characteristics</i>	<i>Plate & Tube</i>	<i>Spiral</i>	<i>Hollow Fibre</i>
Packing density	Moderate	High	Highest
Permeate flux	High	High	Low
Pretreatment	Moderate	High	Highest
Suspended Solid build up	<u>Moderate</u>	High	Highest

Having superior constructional features, the PT Modules also score on Operational Aspects and are far simpler to operate due to absence of elaborate stages of pre-treatment of raw water.

The Plate Tube Membrane system can be used with simple backwash Sand filter and cartridge filters of 10 micron. Any permanent wastewater pre-treatment by chemicals at various points is not required. A higher silt density index SDI-blocking factor of 15 only means that the system has to be cleaned less frequently, normally once every 4 weeks.

The cleaning circuit for the Plate Tube membrane is included in every plant and can be handled simply without any special knowledge demand from operating staff.

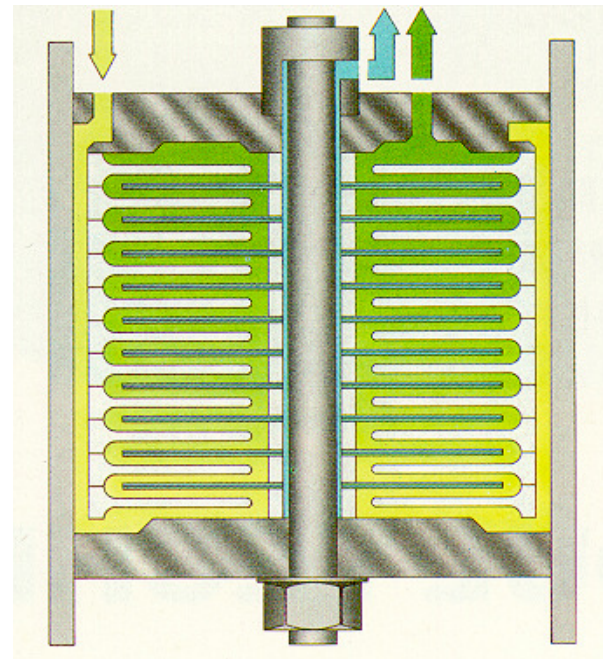

Advantages of Constructional Configuration in ROCHEM's Plate Tube Module:

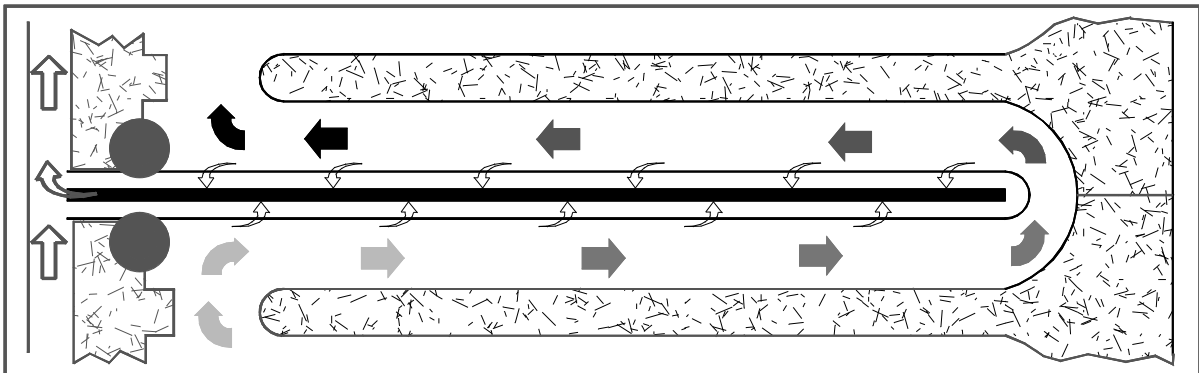

- a. Open channel feed flow path
 - An Open Channel Feed Flow Path Reduces the need for Pre-treatment and Reduces the Possibility of Fouling
 - The Plate Tube has an Open Channel of 1mm
 - A Conventional Module has a 3 - 7 Micron Channel
 - **The Plate Tube has 1500% Greater Clearance**
 - The Plate Tube Allows for More Complete Cleaning

- b. Short flow path
 - Flow Reversal Causes Turbulence, Turbulence Reduces Polarization Concentration
 - The Plate Tube has a 3 Inch Flow Path between Flow Reversals
 - A Conventional Module has a 40 Inches Flow Path

- c. Minimal areas of no flow
 - Zones of No Flow Increase the Rate of Fouling and Catch Bacteria and Colloidal Material
 - Contact with the Membrane Creates Zones of No Flow
 - The Plate Tube has Minimal Contact with Membrane Surface
 - The Feed Spacer In a Conventional Module has Tremendous Contact with the Membrane Surface

The PT module offers additional unique advantages over other types of membranes:

1. **Simplified pre filtration:** Can smoothly operate with waters having Silt Density Index (SDI) of 15-20 as against 3-5 and turbidity of 4-5 NTU as against maximum 1 NTU tolerated by other membrane modules.
2. **No chemical operating costs:** No chemical pre-treatment is required for wastewater applications and also other difficult water qualities.

3. **High recovery rates:** High recovery rates (i.e. m³ of Permeate produced/100m³ of feed pumped in) are typically achieved with PT. This means lower energy consumption per unit pure water produced, and contributes towards lower pumping and maintenance costs in the case of PT.
4. **Longer Membrane Life:** The Membrane is open channel type and raw water-flow in series. Due to fluid dynamics obtained with this design the suspended solids carried in the feed water do not clog or easily settle over the membrane surface.

Thus, it can accept much worse waters than the SW/HFF types other types as is evident from threshold values of Silt Density Index (SDI) and Turbidity (NTU) as under:

	<u>SDI (% per min)</u>	<u>Turbidity (NTU)</u>
HFF	1 - 3	1
SW	1- 3	1
PT (Rochem)	20	5

It is known fact that makers of hollow fibre or spiral wound membrane system offer a 3 years to 5 years guarantee for the membranes' life. This will be more or less an optical illusion because this guarantee is based on the operation of natural wastewater with a SDI-factor less than 3. Normally,

Natural wastewater will be aggressive against the membranes' material. But the guarantee will only cover the durability of the membranes' material against all substances inside natural clean wastewater, and not a clogging of a membrane which will be the responsibility of the operator. Therefore such guarantees are of little help or value to the operator and maintainer.

5. **Lower membrane replacement costs:** Conventional membrane elements are life-sealed at manufacture so the complete element must be replaced at relatively high cost, but the PT module system offers the possibility of replacing individual sheets of membrane at a fraction of the cost.
6. **Better Chemical Cleaning:** PT Configurations have design features which minimize fouling to a level where in situ chemical cleaning restores original membrane performance and provides a long operating life; SW and HFF membranes with inherently constricted flow passages are prone to heavy fouling which is only partially handled by chemical cleaning and thus have a pronounced tendency to choke and have limited operating life.
7. **Lower Maintenance Cost:** With PT Module, even after the expected life, it is possible to identify the damaged membranes and replace only these membrane envelopes, rather than the total set in the stack. In SW or HFF types, which are factory - sealed for life, the whole module is to be rejected. Thus the replacement cost of membranes is significantly higher for SW and HFF types compared to PT.
8. **Low Operating Costs:** The above points, reduced pre-treatment and longer membrane life, clearly show that the operating costs of the plant are significantly lower than the SW /HFF configurations.
9. **Easy Access to All Components including membranes:** Modules can easily be opened up to permit exchange or inspection of each membrane sheet. (This is not possible in SW/HFF, since these are factory sealed)
10. **Compact and Modular construction:** The unique design offers versatile features like superior flux, smaller foot print, easy handling, ease of scalability, replacability and isolation in case of fault.

Aspects of Comparison between ROCHEM PT-RO and Conventional Spiral RO

Limiting Parameters	ROCHEM PT-RO	CONVENTIONAL SPIRAL RO
SDI	SDI < 15	SDI < 3
Turbidity	Turbidity < 20 NTU	Turbidity < 0.1 NTU
TSS	TSS < 500 ppm	TSS < 50 ppm
COD	COD < 25000 ppm (solvent free)	COD < 50 ppm
Flexibility	It can handle TDS from 2000-35000 ppm without hardware change.	It can only operate at designed specifications or lower than it.
Fouling Potentials	Low due to Turbulent Fluid dynamics.	High fouling and frequent cleaning finally result in low flux rate.
Flux flowing channel	Distance between membrane layers 1 mm.	Distance between membrane layers 3-7 micron.
Area of no flow	PT RO do not have no flow zones in their configuration.	SP RO due to Mesh Space creating no flow zone which result in low permeate flux and poor cleaning.
Ease of accessing membranes	Reaching/observation of membrane layer are possible hence manual cleaning of membrane is also possible.	They are factory sealed.
Pre-treatment	No or low pre-treatments.	Heavy pretreatment includes UF, Chlorination, De-chlorination etc.
Automation	Fail safe unattended operation, PLC provided.	Manual operations, PLC may be provided.
Space requirement	Skid Mounting Units, Lower footprints.	High Footprints due to many pre-treatments.
Cost of membrane replacement	Low due to higher membrane life.	High due to lower membrane life.
Cleaning Efficiency	High	Low
Comprehensive O & M	Membrane Replacement is possible.	Membrane replacement may not be possible.
Life cycle recoveries	Due to technological advantages ROCHEM PT RO System can give higher recovery than Spiral RO.	Lower recovery due to above disadvantages.
Cost of reject treatment/disposal	Low due to high recovery	High due to low recovery

Rochem RO Installations to recycle MLD Capacity Effluents:

Sr. No.	Client	Capacity, KLD
1.	Radico Khaitan Ltd. (Unit- Rampur)	1176
2.	Grasim Industries Ltd., Nagda	2600
3.	Grasim Industries Ltd., Nagda	3500
4.	Disti Chemi Process Engineering Pvt. Ltd. for M/s. Pad. Dr. Vikhe Patil SSK Ltd., Ahmednagar	1523
5.	Concord Enviro FZE - Honest Deerivatives, Jalgaon	1100
6.	Concord Enviro FZE - Honest Deerivatives, Jalgaon	1100
7.	Tata Motors, Chikali	1600
8.	Continental Carbon India Ltd., Ghaziabad, U.P.	1340
9.	Jubilant Organosys Ltd., Gajraula, U. P.	1350
10.	Jubilant Organosys Ltd., Gajraula, U. P.	1200
11.	N.V. Distilleries & Breweries Ltd., U.P.	1000
12.	Roquette Riddhi Siddhi Pvt. Ltd. Uttarakhand	1500
13.	Gulshan Polyols Ltd., Jhagadia	1100
14.	Gujarat Ambuja Exports Ltd., Hubli	1100
15.	Kasyap Sweetners Ltd., Badnawar	1100
16.	Roquette Riddhi Siddhi Pvt. Ltd., Gokak	1350
17.	Roquette Riddhi Siddhi Pvt. Ltd., Gokak	1722
18.	STRIDES SHASUN LTD., Pondicherry	1105
19.	BHOPAL GLUES & CHEMICALS PVT. LTD., M.P.	1100

Section 3: Block Diagram

EFFLUENT TREATMENT UNIT WITH REVERSE OSMOSIS FOR RECYCLE

ROCHEM PT-RO Membrane System for Effluent Recycle.

Capacity – 1200 cum/day @ 22 hrs. Operation

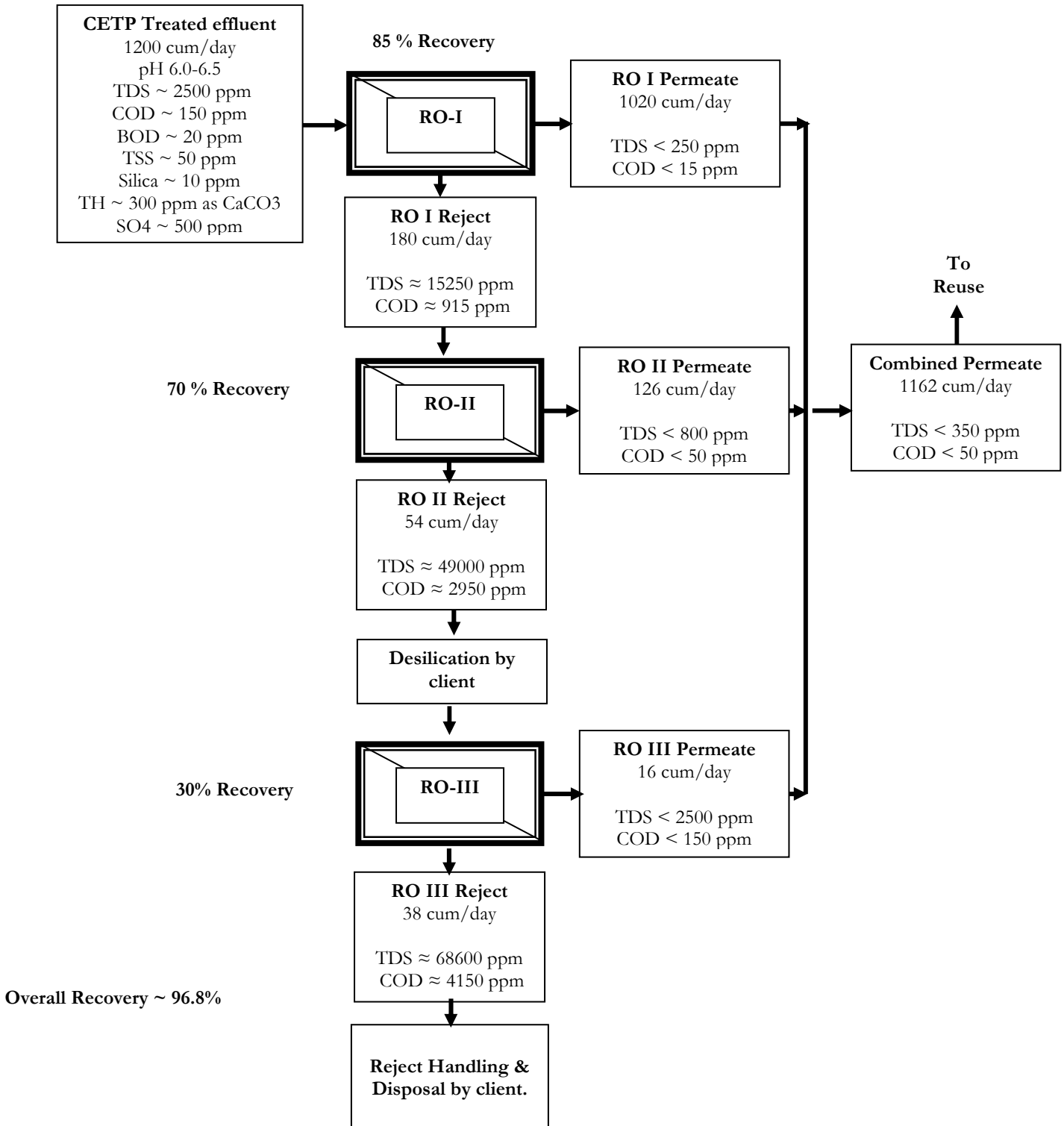

Section 4: Technical Offer

**ROCHEM RO MEMBRANE SYSTEM FOR EFFLUENT RECYCLE.
(Fully automatic RO with SCADA)**

Input Effluent to RO-I System	:	CETP treated effluent @ pH of 6.0 – 6.5 max. (by HCl by client)
Input Effluent Capacity	:	1200 cum/day
RO Input Effluent Quality	:	
TDS		< 2500 ppm
COD		< 150 ppm
RO Permeate Capacity	:	1020 cum/day
RO Permeate Quality	:	Colourless
TDS*		< 250 ppm
COD*		< 15 ppm
Recovery of RO Permeate	:	85%

Input Effluent to RO-II System	:	RO-I Reject @ pH of 6.0 – 6.5 max. (by HCl by client)
Input Effluent Capacity	:	180 cum/day
RO Input Effluent Quality	:	
TDS		< 15250 ppm
COD		< 915 ppm
RO Permeate Capacity	:	126 cum/day
RO Permeate Quality	:	Colourless
TDS*		< 800 ppm
COD*		< 50 ppm
Recovery of RO Permeate	:	70 %

Input Effluent to RO-III System	:	RO-II Reject @ pH of 6.0 – 6.5 max. (by HCl by client)
Input Effluent Capacity	:	54 cum/day
RO Input Effluent Quality	:	
TDS		< 49000 ppm.
COD		< 2950 ppm.
RO Permeate Capacity	:	16 cum/day
RO Permeate Quality	:	Colourless
TDS*		< 2500 ppm
COD*		< 150 ppm
Recovery of RO Permeate	:	30 %

Note:

- System recovery is designed based on feed data provided by client.
- * Permeate quality is subject to change based on pilot trials on actual effluent.
- **Solvents, oxidizing agents assumed to be Nil, other heavy metals like strontium, barium etc. assumed to be absent. Free Chlorine assumed to be NIL.
- **Effluents containing Sizing, Desizing, Finishing Streams, Softeners, Cationic chemicals, are not compatible with TFC RO membranes, and the system warranty will be void, in case such streams, effluents, are subjected to the membranes untreated.**
- You shall provide Power & HCl as required free of cost.
- This design is subject to input effluent quality. Any deviation in the effluent feed quality will have a direct effect on the system recovery.
- All the civil units' related work required shall be done by you.
- **This price is Unpacked Ex-works based on Nil customs duty. Necessary EPCG documents to be provided by your goodselves.**

The system shall have state of art, self diagnostic PLC based safety features built in to make it more user friendly and more reliable with minimum downtime.

List and Specification of Main Components

Unit Type : RO-I 1200 cum/day
Hours of Operation : 22 hrs
Recovery : 85%

List of Components

Item	Description
1.	Feed Water Handling & Treatment System
1.1.	Feed pump – client scope
1.2.	Filter pump
1.3.	Sand filter
1.4.	Cartridge filter
1.5.	Anti-scalant Dosing System
1.6.	Acid Dosing
2.	RO System
2.1.	High pressure pump system
2.2.	Servo motor valve
2.3.	Membrane modules (ST-PT Module)
2.4.	Inline Booster Pump
3.	Permeate Water Post Treatment equipment.
3.1.	Intermediate Tank & Pump
3.2.	Degasser system
3.3.	Product water pump
4.	Cleaning system
5.	Control System & Instrumentation
5.1.	Processor control system
5.2.	Measuring system
6.	Piping
6.1.	Low pressure piping
6.2.	High pressure piping

Note: The given details are indicative. Quantities, makes and sizes may be altered during detailed engineering keeping overall performance and reliability unaltered.

1. Feed Water Handling & Treatment System

1.1. Filter pump

The filter pump is designed to supply the filter system and high pressure pump with sufficient pre-pressure and consists of a multi-stage centrifugal pump. Min 3.0 bar suction pressure is required for the pump.

Quantity : (No.) 1 W + 1 HS

Specification Pump

Make : Grundfos /Shakti/ Equivalent
 Type : Multi stage centrifugal Pump
 Material : SS 316 internal parts
 Designed capacity max : (lph) 54545
 Pump pressure : (bar) 4.0 – 4.5
 Rotation : (RPM) 2900
 Motor : Grundfos/Equivalent

Specification Drive

Type : Three Phase A.C. motor
 Voltage / Frequency : (V/Hz) 415 / 50
 Output : (kW) 11
 Speed : (RPM) 2900
 Insulation : class F
 Class of protection : IP 55

1.2. Sand filter

The Sand filter unit is designed for rapid filtration of the effluent without choking. The filter system is supplied with gauges and diverter valves. The filter is equipped with a backwashing system for removal of solids trapped.

Quantity : 1 Set W + 1 Set HS

Specification

Make : Rochem/ Equivalent
 Material Vessel : FRP
 Designed flow rate. : (lph) 54545
 Operating pressure designed : (bar) 4.0 – 6.0
 Operating pressure max. : (bar) 8

1.3. Cartridge filter

The cartridge filter is designed to remove any suspended matter to reduce organic or inorganic fouling on the membranes. The cartridge filter is supplied with sufficient pre-pressure from the filter pump.

Quantity : 1 Set

Specification

Make : Rochem/ Equivalent
 Material Filter Element : PP
 Material Housing : PP FRP
 Type of Element : Wound Type 10 micron
 Size of Housing : suitable

1.4. Anti-scalant Dosing System

The RO membrane is susceptible to fouling due to precipitation of sparingly soluble salts present in the feed water. Anti-scalant is dosed upstream of the RO membrane to control scale formation.

Quantity : 1 No.

Specification

Tank Capacity : 100 Lit HDPE
 Dosing by : Pumping
 Pump Make : Chensoie/Edose/Equivalent
 Pump Capacity : 0-5 LPH at 6 bar
 Power Supply : 230 V /50 HZ /1 phase

1.5. Acid Dosing (Only For Fine Tuning of feed)

This system is to ensure the fine tuning of the pH of the feed to 6.0-6.5 pH. Acid (HCl) required shall be provided by client.

Quantity : 1 No.

Specification

Make : ROCHEM/Equivalent
 Dosing by : Injector system
 Tank Capacity : 200 Lit
 Tank MOC : HDPE

2. RO System

2.1. High pressure pump system

The pump system is designed for reliable 24 hours operation with corrosion resistant material of latest standard for use on high TDS water applications.

Quantity : (No.) 1 set W + 1 single SS

Specification Pump

Make : OSNA/Grundfos/ Equivalent Pump
 Type : Centrifugal pump
 Material : SS
 Designed capacity max. : (lph) 54545
 Pump pressure max. : (bar) 30-40

Specification Drive

Type : Three Phase A.C. motor
 Voltage / Frequency : (V/Hz) 415 / 50
 Power : (kW) 60
 Speed : (RPM) 2900
 Insulation : class F
 Class of protection : IP 55

2.2. Servo motor valve

This valve is used to control recovery of system by operating pressure of PT Module. It is placed on the reject discharge line.

Bushing connection Female : 1" NPT
 Nominal Pressure : (Bar) 70 Bar
 Material Housing : SS316
 Material of inner Parts : SS316
 Electrical Actuator Voltage : (V) 220
 Frequency : (Hz) 50/60
 Limit Switch Pos. Open/Closed : One Set
 Way Switch Pos. Open/closed : One Set

2.3. Membrane modules (ST-PT Module)

Specification Module

Type : ST Module
 Operating pressure max. : (bar) 25
 Hydraulic connection : flexible hose
 Quantity : 1 Set

Specification Module

Type	:	PT Module
Material module plates	:	Advanced Thermoplastic with high coefficient of Thermal expansion.
End flanges	:	Stainless Steel
Tie rod	:	Stainless Steel
Feed flow nominal	:	(lph) 750 – 800
Operating pressure max.	:	(bar) 60 – 65
Hydraulic connection	:	flexible hose
Membrane Type	:	TFC – Polyamide – RO
Quantity	:	One Set

2.4. Inline Booster Pump

It is used to increase pressure of subsequent stages, if required.

Quantity	:	1 set W + 1 single SS
----------	---	-----------------------

Specification Pump

Make	:	Dickow / Grundfos /Shakti/ Equivalent
Type	:	Centrifugal Pump
Material	:	SS 316
Pump pressure max.	:	(bar) 8.0 /suitable

3. Permeate Water Post Treatment equipment.

3.1. Intermediate Tank & Pump (Common for RO-I, II, III)

Intermediate tank is provided to avoid backpressures on RO membranes. The intermediate pump is designed to supply RO permeate to degasser tank with sufficient pressure and consists of centrifugal pump.

Specification Tank

Quantity	:	(No.) 1
Tank Capacity	:	(KL) 30 KL RCC by client

Specification Pump

Quantity	:	1 W + 1 HS
Make	:	Shakti /Equivalent
Type	:	Centrifugal Pump
Material	:	Stainless steel internal parts
Designed capacity max.	:	(lph) 52818
Pump pressure max.	:	(bar) 1.5
Output	:	(kW) 5.5

Product Water Transfer System Frame installation

- Product Water Tank as degasser sump, with level indicator and high and low level switches for signaling to PLC.
- Product Water Pump & Motor

3.2. Degasser system

The output water (permeate) will contain a concentration of free carbon dioxide CO₂ due to destabilized hardness salts like Ca(HCO₃)₂. To prevent the corrosion of coated iron pipes a degasser system is installed. The degasser strips the CO₂ in the permeate resulting in neutral pH of permeate from the system.

The system consists of a degasser tower and storage tank (RCC tank to be supplied by client) with level indicator and high and low level switches for signalling to PLC.

Specification

Quantity	:	1 Set
Tower MOC	:	FRP/PP/PVC
Tower Quantity	:	1 Set
Blower Quantity	:	1 Set
Blower MOC	:	FRP
Degassing Tank	:	1 No.
Tank MOC	:	RCC (civil tank by client)
Tank Size	:	100 cum

3.3. Product water pump

The product water pump is designed to supply the permeate water tank filling system with sufficient pressure and consists of a centrifugal pump. The pump takes the suction from the Permeate water Tank.

Specification Pump

Quantity	:	1 W + 1 HS
Make	:	Shakti/ Equivalent
Type	:	Centrifugal pump
Material	:	Stainless steel internal parts
Designed capacity max.	:	(lph) 54545
Pump pressure max.	:	(bar) 2.0-3.0
Output	:	(kW) 11

4. Cleaning system

The system is fitted with process controls to enable efficient flushing and cleaning of membranes as required for efficient operation of system and maintenance of membrane conditions.

The same is enabled by PLC operations in the control system loops.

5. Control System & Instrumentation

5.1. Processor control system

The process controller is the microprocessor (PLC) which controls and operates the following functions: -

- Operation of filter pump
- Operation of high pressure pump and other system drives sequentially based on operating mode
- Operation of control valves to regulate operating pressure / flow based on mode of operation between Normal, Flushing, Cleaning
- Overall system failsafe control by flow, pressure monitoring.

Make – Schnider - Telemecanique/Allen Bradley

5.2. Measuring system

The measuring systems consisting of Pressure gauges, switches, Flow indicators, etc, enable efficient and simple desired parameter logging, and support control system by feedback to PLC.

Make

Pressure gauges, Transmitter	:	Mass / Wika /Equivalent
Pressure Switch	:	Telemecanique/ Orion/Equivalent
Flow indicators	:	George Fischer /Equivalent
Conductivity & pH meters	:	MMP / Eutech / Equivalent
Flow Totalizer	:	George Fischer/Equivalent

6. Piping

6.1. Low pressure piping

The low pressure valves and piping system is corrosion proof and fabricated of PVC/Rubber/ PU with a pressure stage of 6 bar at 40^o C and test pressure of 9 bar max.

Make - Local

6.2. High pressure piping

The high pressure piping and fittings are fabricated of special stainless steel & piping of wire braided rubber with highest standard corrosion resistance suitable for operation in water with a high salt content. The pressure in high pressure stage is up to 60 bar max.

Unit Type : RO-II 180 cum/day
Hours of Operation : 22 hrs
Recovery : 70%

List of Components

Item	Description
1.	Feed Water Handling & Treatment System
1.1.	Feed pump – client scope
1.2.	Filter pump
1.3.	Cartridge filter
1.4.	Anti-scalant Dosing System
1.5.	Acid Dosing
2.	RO System
2.1.	High pressure pump system
2.2.	Servo motor valve
2.3.	Membrane modules (ST-PT Module)
2.4.	Inline Booster Pump
3.	Permeate Water Post Treatment equipment. (Common for RO-I, II, III)
4.	Cleaning system
5.	Control System & Instrumentation
5.1.	Processor control system
5.2.	Measuring system
6.	Piping
6.1.	Low pressure piping
6.2.	High pressure piping

Note: The given details are indicative. Quantities, makes and sizes may be altered during detailed engineering keeping overall performance and reliability unaltered.

1. Feed Water Handling & Treatment System

1.1. Filter pump

The filter pump is designed to supply the filter system and high pressure pump with sufficient pre-pressure and consists of a multi-stage centrifugal pump. Min 3.0 bar suction pressure is required for the pump.

Quantity : (No.) 1 W + 1 HS

Specification Pump

Make : Grundfos /Shakti/ Equivalent
 Type : Multi stage centrifugal Pump
 Material : SS 316 internal parts
 Designed capacity max : (lph) 8181
 Pump pressure : (bar) 4.0 – 4.5
 Rotation : (RPM) 2900
 Motor : Grundfos/Equivalent

Specification Drive

Type : Three Phase A.C. motor
 Voltage / Frequency : (V/Hz) 415 / 50
 Output : (kW) 2.2
 Speed : (RPM) 2900
 Insulation : class F
 Class of protection : IP 55

1.2. Cartridge filter

The cartridge filter is designed to remove any suspended matter to reduce organic or inorganic fouling on the membranes. The cartridge filter is supplied with sufficient pre-pressure from the filter pump.

Quantity : 1 Set W + 1 Set HS

Specification

Make : Rochem/ Equivalent
 Material Filter Element : PP
 Material Housing : PP FRP
 Type of Element : Wound Type 10 micron
 Size of Housing : suitable

1.3. Anti-scalant Dosing System

The RO membrane is susceptible to fouling due to precipitation of sparingly soluble salts present in the feed water. Anti-scalant is dosed upstream of the RO membrane to control scale formation.

Quantity : 1 No.

Specification

Tank Capacity : 100 Lit HDPE
 Dosing by : Pumping
 Pump Make : Chensoie/Edose/Equivalent
 Pump Capacity : 0-5 LPH at 6 bar
 Power Supply : 230 V /50 HZ /1 phase

1.4. Acid Dosing (Only For Fine Tuning of feed)

This system is to ensure the fine tuning of the pH of the feed to 6.0-6.5 pH. Acid (HCl) required shall be provided by client.

Quantity : 1 No.

Specification

Make : ROCHEM/Equivalent
 Dosing by : Injector system
 Tank Capacity : 200 Lit
 Tank MOC : HDPE

2. RO System

2.1. High pressure pump system

The pump system is designed for reliable 24 hours operation with corrosion resistant material of latest standard for use on high TDS water applications.

Quantity : (No.) 1 set W + 1 single SS

Specification Pump

Make : Grundfos/CAT Pump – Japan / Equivalent Pump
 Type : Centrifugal/Triplex plunger pump
 Material : SS
 Designed capacity max. : (lph) 8181
 Pump pressure max. : (bar) 60

Specification Drive

Type : Three Phase A.C. motor
 Voltage / Frequency : (V/Hz) 415 / 50
 Power : (kW) 18
 Speed : (RPM) 2900
 Insulation : class F

Class of protection : IP 55

2.2. Servo motor valve

This valve is used to control recovery of system by operating pressure of PT Module. It is placed on the reject discharge line.

Bushing connection Female	:	1" NPT
Nominal Pressure	:	(Bar) 70 Bar
Material Housing	:	SS316
Material of inner Parts	:	SS316
Electrical Actuator Voltage	:	(V) 220
Frequency	:	(Hz) 50/60
Limit Switch Pos. Open/Closed	:	One Set
Way Switch Pos. Open/closed	:	One Set

2.3. Membrane modules (PT Module)

Specification Module

Type	:	PT Module
Material module plates	:	Advanced Thermoplastic with high co-efficient of Thermal expansion.
End flanges	:	Stainless Steel
Tie rod	:	Stainless Steel
Feed flow nominal	:	(lph) 750 – 800
Operating pressure max.	:	(bar) 60 – 65
Hydraulic connection	:	flexible hose
Membrane Type	:	TFC – Polyamide – RO
Quantity	:	One Set

2.4. Inline Booster Pump

It is used to increase pressure of subsequent stages, if required.

Quantity	:	1 set W + 1 single SS
----------	---	-----------------------

Specification Pump

Make	:	Dickow / Grundfos /Shakti/ Equivalent
Type	:	Centrifugal Pump
Material	:	SS 316
Pump pressure max.	:	(bar) 8.0 /suitable

3. Cleaning system

The system is fitted with process controls to enable efficient flushing and cleaning of membranes as required for efficient operation of system and maintenance of membrane conditions.

The same is enabled by PLC operations in the control system loops.

4. Control System & Instrumentation

4.1. Processor control system

The process controller is the microprocessor (PLC) which controls and operates the following functions: -

- Operation of filter pump
- Operation of high pressure pump and other system drives sequentially based on operating mode
- Operation of control valves to regulate operating pressure / flow based on mode of operation between Normal, Flushing, Cleaning
- Overall system failsafe control by flow, pressure monitoring.

Make – Schnider - Telemecanique/Allen Bradley

4.2. Measuring system

The measuring systems consisting of Pressure gauges, switches, Flow indicators, etc, enable efficient and simple desired parameter logging, and support control system by feedback to PLC.

Make

Pressure gauges, Transmitter	:	Mass / Wika /Equivalent
Pressure Switch	:	Telemecanique/ Orion/Equivalent
Flow indicators	:	George Fischer /Equivalent
Conductivity & pH meters	:	MMP / Eutech / Equivalent
Flow Totalizer	:	George Fischer/Equivalent

5. Piping

5.1. Low pressure piping

The low pressure valves and piping system is corrosion proof and fabricated of PVC/Rubber/ PU with a pressure stage of 6 bar at 40^o C and test pressure of 9 bar max.

Make - Local

5.2. High pressure piping

The high pressure piping and fittings are fabricated of special stainless steel & piping of wire braided rubber with highest standard corrosion resistance suitable for operation in water with a high salt content. The pressure in high pressure stage is up to 60 bar max.

Unit Type : RO-III 54 cum/day
Hours of Operation : 20 hrs
Recovery : 30%

List of Components

Item	Description
1.	Feed Water Handling & Treatment System
1.1.	Feed pump – client scope
1.2.	Filter pump
1.3.	Cartridge filter
1.4.	Anti-scalant Dosing System
1.5.	Acid Dosing
2.	RO System
2.1.	High pressure pump system
2.2.	Servo motor valve
2.3.	Membrane modules (ST-PT Module)
2.4.	Inline Booster Pump
3.	Permeate Water Post Treatment equipment. (Common for RO-I, II, III)
4.	Cleaning system
5.	Control System & Instrumentation
5.1.	Processor control system
5.2.	Measuring system
6.	Piping
6.3.	Low pressure piping
6.4.	High pressure piping

Note: The given details are indicative. Quantities, makes and sizes may be altered during detailed engineering keeping overall performance and reliability unaltered.

1. Feed Water Handling & Treatment System

1.1. Filter pump

The filter pump is designed to supply the filter system and high pressure pump with sufficient pre-pressure and consists of a multi-stage centrifugal pump. Min 3.0 bar suction pressure is required for the pump.

Quantity : (No.) 1 W + 1 HS

Specification Pump

Make : Grundfos /Shakti/ Equivalent
 Type : Multi stage centrifugal Pump
 Material : SS 316 internal parts
 Designed capacity max : (lph) 2700
 Pump pressure : (bar) 4.0 – 4.5
 Rotation : (RPM) 2900
 Motor : Grundfos/Equivalent

Specification Drive

Type : Three Phase A.C. motor
 Voltage / Frequency : (V/Hz) 415 / 50
 Output : (kW) 0.75
 Speed : (RPM) 2900
 Insulation : class F
 Class of protection : IP 55

1.2. Cartridge filter

The cartridge filter is designed to remove any suspended matter to reduce organic or inorganic fouling on the membranes. The cartridge filter is supplied with sufficient pre-pressure from the filter pump.

Quantity : 1 Set W + 1 Set HS

Specification

Make : Rochem/ Equivalent
 Material Filter Element : PP
 Material Housing : PP FRP
 Type of Element : Wound Type 10 micron
 Size of Housing : suitable

1.3. Anti-scalant Dosing System

The RO membrane is susceptible to fouling due to precipitation of sparingly soluble salts present in the feed water. Anti-scalant is dosed upstream of the RO membrane to control scale formation.

Quantity : 1 No.

Specification

Tank Capacity : 100 Lit HDPE
 Dosing by : Pumping
 Pump Make : Chensoie/Edose/Equivalent
 Pump Capacity : 0-5 LPH at 6 bar
 Power Supply : 230 V /50 HZ /1 phase

1.4. Acid Dosing (Only For Fine Tuning of feed)

This system is to ensure the fine tuning of the pH of the feed to 6.0-6.5 pH. Acid (HCl) required shall be provided by client.

Quantity : 1 No.

Specification

Tank Capacity : 100 Lit HDPE
 Dosing by : Pumping
 Pump Make : Chensoie/Edose/Equivalent
 Pump Capacity : 0-5 LPH at 6 bar
 Power Supply : 230 V /50 HZ /1 phase

2. RO System

2.1. High pressure pump system

The pump system is designed for reliable 24 hours operation with corrosion resistant material of latest standard for use on high TDS water applications.

Quantity : (No.) 1 set W + 1 single SS

Specification Pump

Make : CAT Pump – Japan /Wanner/ Equivalent
 Type : Plunger/diaphragm pump
 Material : SS
 Designed capacity max. : (lph) 2700
 Pump pressure max. : (bar) 75

Specification Drive

Type : Three Phase A.C. motor
 Voltage / Frequency : (V/Hz) 415 / 50
 Power : (kW) 6.8
 Speed : (RPM) 2900

Insulation	:	class F
Class of protection	:	IP 55

2.2. Servo motor valve

This valve is used to control recovery of system by operating pressure of PT Module. It is placed on the reject discharge line.

Bushing connection Female	:	1” NPT
Nominal Pressure	:	(Bar) 80 Bar
Material Housing	:	SS316
Material of inner Parts	:	SS316
Electrical Actuator Voltage	:	(V) 220
Frequency	:	(Hz) 50/60
Limit Switch Pos. Open/Closed	:	One Set
Way Switch Pos. Open/closed	:	One Set

2.3. Membrane modules (PT Module)

Specification Module

Type	:	PT Module
Material module plates	:	Advanced Thermoplastic with high coefficient of Thermal expansion.
End flanges	:	Stainless Steel
Tie rod	:	Stainless Steel
Feed flow nominal	:	(lph) 750 – 800
Operating pressure max.	:	(bar) 75
Hydraulic connection	:	flexible hose
Membrane Type	:	TFC – Polyamide – RO
Quantity	:	One Set

2.4. Inline Booster Pump

It is used to increase pressure of subsequent stages, if required.

Quantity	:	1 set W + 1 single SS
----------	---	-----------------------

Specification Pump

Make	:	Dickow / Grundfos /Shakti/ Equivalent
Type	:	Centrifugal Pump
Material	:	SS 316
Pump pressure max.	:	(bar) 8.0 /suitable

3. Cleaning system

The system is fitted with process controls to enable efficient flushing and cleaning of membranes as required for efficient operation of system and maintenance of membrane conditions.

The same is enabled by PLC operations in the control system loops.

4. Control System & Instrumentation

4.1. Processor control system

The process controller is the microprocessor (PLC) which controls and operates the following functions: -

- Operation of filter pump
- Operation of high pressure pump and other system drives sequentially based on operating mode
- Operation of control valves to regulate operating pressure / flow based on mode of operation between Normal, Flushing, Cleaning
- Overall system failsafe control by flow, pressure monitoring.

Make – Schneider - Telemecanique/Allen Bradley

4.2. Measuring system

The measuring systems consisting of Pressure gauges, switches, Flow indicators, etc, enable efficient and simple desired parameter logging, and support control system by feedback to PLC.

Make

Pressure gauges, Transmitter	:	Mass / Wika /Equivalent
Pressure Switch	:	Telemecanique/ Orion/Equivalent
Flow indicators	:	George Fischer /Equivalent
Conductivity & pH meters	:	MMP / Eutech / Equivalent
Flow Totalizer	:	George Fischer/Equivalent

5. Piping

5.1. Low pressure piping

The low pressure valves and piping system is corrosion proof and fabricated of PVC/Rubber/ PU with a pressure stage of 6 bar at 40° C and test pressure of 9 bar max.

Make - Local

5.2. High pressure piping

The high pressure piping and fittings are fabricated of special stainless steel & piping of wire braided rubber with highest standard corrosion resistance suitable for operation in water with a high salt content. The pressure in high pressure stage is up to 75 bar max.

LIST of CIVIL UNITS

Sr. No.	Particulars	Tank Volume
1	CETP Treated Effluent Storage Tank (RO1 Feed Tank)	450 m ³
2	Common Intermediate Tank for RO-I, II, III	15 m ³
3	Common Degasser Sump for RO-I, II, III (Note: In case permeate storage tank of higher retention time or an additional tank is required the same to be as per your requirement. Permeate transfer pump in your scope. Rochem will provide rinse pump which has 2-3 bar discharge pressure)	100 m ³
4	RO-I Reject Tank (Feed tank for RO-II)	30 m ³
5	RO-II Reject Tank	10 m ³
6	RO-III Feed Tank (Treated water storage tank of pre-treatment plant)	10 m ³
7	RO-III Reject Tank (Feed tank for Evaporation)	15 m ³
8	Misc. foundations	
9	Panel Room	
10	RO Shed	25MX15MX4.5M

Note:

- Above is an indicative list & Subject to change on detail design
- Civil works in client scope

Section 5: Battery Limits, Scope & Exclusions

BATTERY LIMITS & EXCLUSIONS:

Battery Limits:

CETP Treated Effluent	: Incoming Line up to RO Skid (by client)
Transfer of Reject to Pre-treatment plant & back	: by client
RO Permeate	: At Degasser Tank (by Rochem). Tank considered near to RO shed.
RO final reject	: To further treatment/ disposal (by client)
Utilities including drinking water & power	: Upto the Treatment plant site. (by client)

Scope:

1. Design, Engineering, procurement & Supply of electro-mechanical, instrumentation & piping within battery limits
2. Supervision of Erection & commissioning

Exclusions: Please note the following are outside battery limits and are not included in our scope:

1. Dismantling of existing Structures if any.
2. Site Development including any cutting, filling, grading, piling etc. at site.
3. All approach Roads / Access to Site.
4. All civil works including plant foundations, piping & wiring to & from the plant.
5. Internal Water Supply Network.
6. Pressurised supply of feed through suitable piping at plant skid inlet i.e. feed pump on the feed tank. Feed supply at plant skid inlet at 3 bar pressure
7. Piping to and from plant.
8. Piping from degasser outlet tank and thereafter to storage tanks by client.
9. Storage facilities for providing feed, storage of permeate.
10. Facilities for storage of RO-1 & RO-2 rejects (at least 4 hrs. holding time required for reject tanks & max 2.5m depth). Disposal of final rejects by client.
11. Sump tank for Degasser.
12. CIP rinse water will be circulated to ETP by client
13. Supply of moisture free compressed air - 1 CFM @ 4-5 bars

14. Supply & laying of Pipe Supports & clamping, Pipe rack, Cable tray and cable tray support arrangement & Foundation bolts.
15. Earthing grids/strips.
16. Supply and provision of continuous power supply at local panel near plant skid with suitable isolator and protection device.
17. Lodging & Boarding & local transportation for our engineers during installation, Erection & Commissioning.
18. RO Shed with illumination.
19. pH adjustment of feed / permeate by client by means of suitable dosing i.e. Dosing System (injector/pump, tanks, piping, etc.)
20. Settling for TSS reduction & Temperature correction of feed.
21. Acid (HCl) & Reducing agent (if required in case of +ve ORP) to be supplied by client.
22. Utilities such as operating power and other utilities such as fresh water connection for commissioning, plant operation/miscellaneous purpose.
23. Sufficient lighting at the installation site.
24. Unloading at site.
25. Relevant connections from Termination Points.
26. Laboratory Facility including Lab Equipment/Instruments, Chemicals and Staff.
27. Installation and Erection of Plant at Site under ROCHEM supervision. For installation, erection and commissioning client shall provide helpers, fitters, electricians etc.
28. Any other requirements that shall be required and not specifically mentioned in our offer.

Section 6: Specification Unit Parameters Reference RO feed analysis

Sr.	Parameter	Unit	Value
1.	pH	---	6.0 – 6.5 max (by HCl by client)
2.	ORP Value	mV	Negative (by client)
3.	Turbidity	NTU	< 10
4.	Total Suspended Solids	mg/ltr	50 max
5.	Total Dissolved Solids	mg/ltr	2500 max
6.	Total Hardness as CaCO ₃	mg/ltr	300 max (assumed)
7.	Calcium Hardness as CaCO ₃	mg/ltr	180 max
8.	Magnesium Hardness as CaCO ₃	mg/ltr	120 max
9.	M-alkalinity as CaCO ₃	mg/ltr	300 max (assumed)
10.	P-alkalinity as CaCO ₃	mg/ltr	Nil
11.	Chlorides as Cl	mg/ltr	700 max (assumed)
12.	Sulphates as SO ₄	mg/ltr	500 max (assumed)
13.	Iron as Fe	mg/ltr	0.9 max (assumed)
14.	Oil & Grease	mg/ltr	10 max (assumed)
15.	Free chlorine	mg/ltr	Nil
16.	Sodium as Na	mg/ltr	700 max (assumed)
17.	Potassium as K	mg/ltr	10 max (assumed)
18.	Total Silica as SiO ₂ *	mg/ltr	10 max.* (assumed)
19.	Temperature	°C	30-40 °C
20.	COD	mg/ltr	150 max
21.	BOD	mg/ltr	20 max

Note:

- Pre-treatment if required will be in client scope.
- Above parameters are tentative based on feed parameters provided by client
- Solvents, oxidizing agents assumed to be Nil, other heavy metals like strontium, barium etc. assumed to be absent. Free Chlorine assumed to be NIL.
- *In case Silica level is > 10 ppm, recovery will be affected.
- Any change in parameters exceeds the above designed values the recovery of permeate will be affected.
- Derating Temperature – Normal Range 30–40 deg C
Operating Range 30 - 40 deg C
Lower temperature < 30 deg C will lead to higher energy consumption & lower recovery.
Higher temperature > 40 deg C will lead to higher permeate TDS.
- With every drop in 1 °C from 30 °C, there shall be corresponding reduction in 2% recovery.
- **Feed Conditioning By Client (If Required)**
Feed pH to be corrected by using HCl by client.
Feed ORP by Reducing agent SMBS by client

Section 7: Specification Unit Parameters Reference RO Permeate analysis

Sr.	Parameter	Unit	RO-I	RO-II	RO-III
1.	Flow	Cum/day	1020	126	16
2.	pH	---	6.8 – 7.2 max. (depending on feed pH)		
3.	TSS	mg/ltr	Nil	Nil	Nil
4.	Total Dissolved Solids	mg/ltr	< 250	< 800	< 2500
5.	*COD	mg/ltr	< 15	< 50	< 150

Note:

- COD reduction will be by 90–95% from feed levels.
- Permeate quality is subject to change based on pilot trials on actual effluent.
- pH correction of feed/permeate with requisite dosing compound in client scope

Section 8: Price Table

Price for the supply of Rochem RO systems: RO-I - 1200 cum/day RO-II - 180 cum/day RO-III - 54 cum/day	Rs. 335,00,000/- <u>(Rs. Three Crore Thirty Five Lakhs Only),</u> <u>Ex-works</u>
---	--

Note:

Taxes & Duties extra

Civil works by client

Section 9: Commercial Terms & Conditions

1.	PRICES	:	Quoted prices are Unpacked Ex. works Vasai near Mumbai.
2.	TAXATION	:	IGST @ 18% You are requested to pay full tax component within 20 days on receipt of our invoice against Delivery payment. In case the tax part of payment is not received by us within the said time limit then interest shall be charged at 18% per month on the amount corresponding to tax value.
3.	CUSTOMS DUTY	:	3.5% on Basic value in case EPCG documents not provided. In case of EPCG transaction, the completion certificate from local excise range shall be submitted to ROCHEM immediately on commissioning. Any commercial implication for non-submission of this document shall be to customer's account. In case of EPCG Transactions, necessary EPCG documents shall be submitted within 2-3 weeks from the date of receipt of PO.
4.	PACKING & FORWARDING	:	1.5% of total plant cost Extra to Client's account.
5.	FREIGHT CHARGES	:	Extra at actuals to Client's account.
6.	TRANSIT INSURANCE	:	To be arranged by Client
7.	DELIVERY TERMS	:	Within 12 – 14 weeks from the date of receipt of order along with advance payment. Delivery subject to timely approval of drawings & Submission of EPCG documents, if applicable.
8.	PAYMENT	:	50% advance with order Balance Payment plus taxes & duties prior dispatch against Proforma Invoice
9.	INSTALLATION & COMMISSIONING	:	Installation to be undertaken by client under our supervision. We will depute our engineer at site for supervision of the installation and commissioning of the system @ Rs. 5000/- per man day. Lodging, Boarding and Local Transportation, 2nd AC Train Fare to & fro your works, extra at actuals by client Commissioning Trials of 72 hrs only
10.	GUARANTEE/ WARRANTY	:	Our plant warranty is for the period of one year from the date of dispatch as per standard format.
11.	VALIDITY	:	90 days from the date of this Offer.

Section 10: Operation & Maintenance Costs

The break-up of the OPERATION AND MAINTENANCE cost would be as follows:

Particulars		RO-I	RO-II	RO-III
Cleaning Chemicals	:	5.50	8.50	11.50
Spares & Consumables	:	4.50	6.00	07.50
Membrane Replacement	:	6.50	9.00	12.50
Antiscalant	:	1.50	2.50	03.50
*Total Rs./m3 Feed	:	18.00	26.00	35.00
Power Consumption	:	2.0-2.4	3.3-3.6	4.0-4.5
KWH/m3 Feed				

HCl by client extra.

Manpower charges shall be extra.

Note:

- ***Above charges are applicable on O&M, wherein the plant capacity utilisation of > 90% is achieved. In case of < 90% plant utilisation O&M rates shall differ/increase.**
- Above power consumption excludes power for feed & permeate transfer to & from plant.
- The above charges are exclusive of power & utilities and subject to Force Majeure. The above prices/costs are ex-works and are exclusive of taxes & duties which would be extra as applicable, subjected to annual escalation.
- The above charges are exclusive of all Taxes & Duties. GST as applicable shall be extra
- Any future taxes & change in rates of taxes / levies shall be borne by client.

We can undertake complete Operation & Maintenance of the above system by provision of 1 Supervisor in the general shift and 1 Operator per Shift OR Supervise the Operation and Maintenance of the System by provision of 1 Supervisor in the general shift. Both contracts can be inclusive of materials and membranes. Our fees for these services will be provided separately.

We hope the above is in line with your requirements and shall be pleased to provide you with any further assistance that you may so desire.

Thanking you and assuring you of our best services at all times,

Yours faithfully,

FOR ROCHEM SEPARATION SYSTEMS (INDIA) PVT. LTD.

GIRISH THORAT
(GENERAL MANAGER-INDIA)

(e: Quotation/Consultant/SMS/Patliputra/Offer_1.2MLD ZLD_Fatuhaa Rev 02.doc)

WARRANTY

ROCHEM Separation Systems (India) Pvt. Ltd., warrants that this system will produce permeate water within its designed limitations for a period of twelve (12) months from the date of despatch of the system, provided that the system is operated on the feed water of the minimum standard in accordance to the submitted reference analysis and that the operator adheres exactly to the installation, operating and maintenance instructions and recommendations.

Component of the system supplied by Rochem which is found to be defective through poor workmanship or materials, which by its nature may have a shorter life than 12 months, will be repaired or replaced if its performance is proved to be less than normal by industry standards.

This warranty may be voided if the unit is operated with malfunctioning components or controls which results in the system being unable to meet its designed performance. **Effluents containing Sizing, Desizing, Finishing Streams, Softeners, Cationic chemicals, are not compatible with TFC RO membranes, and the system warranty will be void, in case such streams, effluents, are subjected to the membranes untreated.**

ROCHEM will repair or replace the unit or components found to be defective due to bad workmanship or materials on a free of charge ex works basis.

A defective unit or component may be returned, freight prepaid, to ROCHEM for repair or replacement ex-factory, as determined by ROCHEM, should the unit be defective under this warranty.

This warranty does not cover any system or component, which fails due to damage from mishandling, misuse, substandard feed water, improper maintenance or neglect of maintenance, poor or improper installation or incorrect electrical supply. This warranty may also be voided if serial numbers and/or components are found to be mutilated or missing.

The warranty does not cover or apply to consumable items such as filter elements, lubricants, pulsation damper, hp-pump valves and seals, or chemicals used in the operation or maintenance of the system.

The terms of this warranty become effective on despatch of the equipment from our factory.

There are no warranties expressed or implied which go beyond the foregoing statement.
